

Wey Hand Stop
Wey Stop Log
Wey Stop Gate

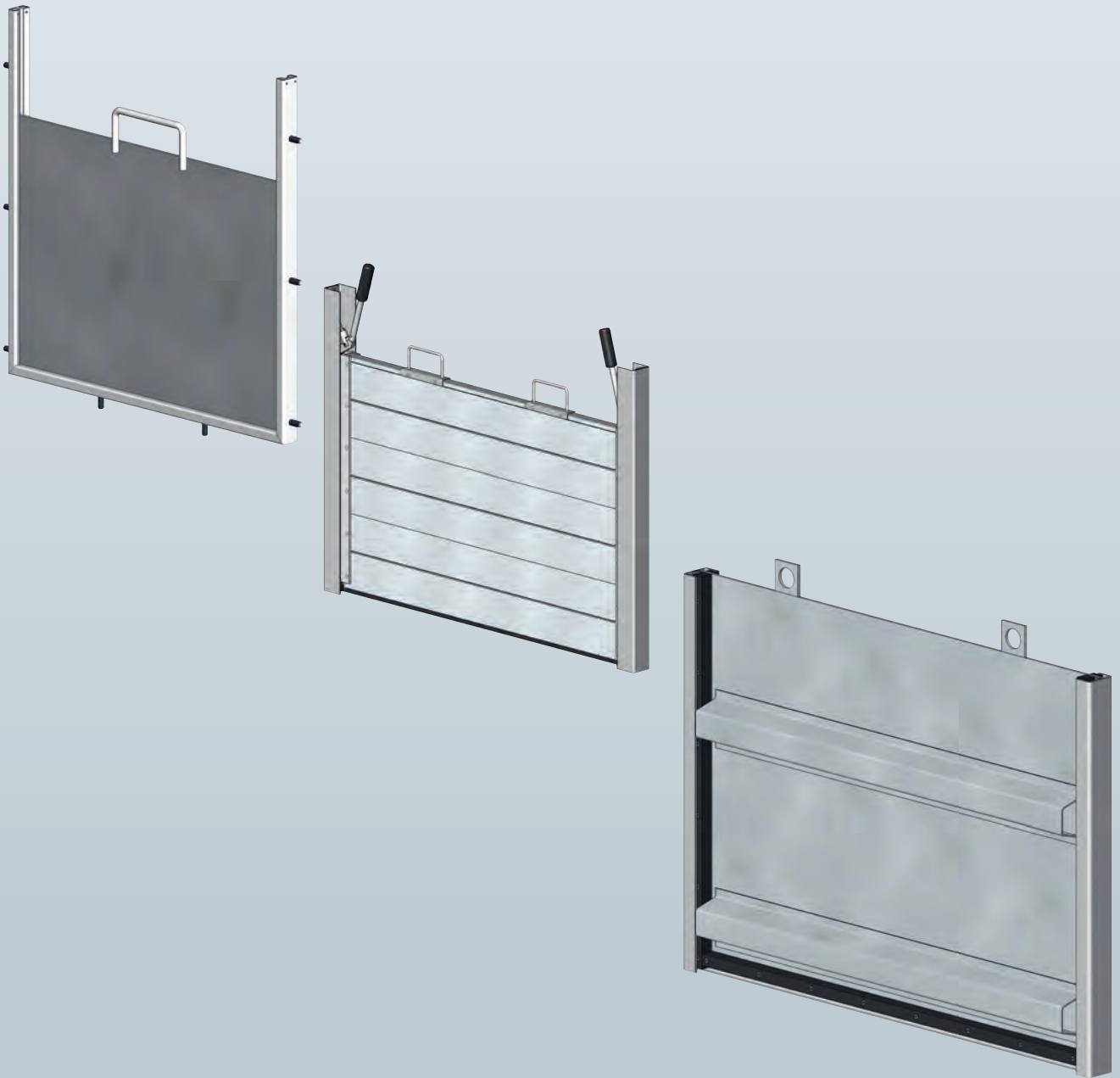

Installation and Instruction Manual

Wey[®] Hand Stop, Wey[®] Stop Log, Wey[®] Stop Gate

1. GENERAL

- 1.1 - Safety
- 1.2 - Designated service

2. TRANSPORTATION, STORAGE

- 2.1 - Transportation
- 2.2 - Storage

3. INSTALLATION

- 3.1 - Preparation before installation
- 3.2 - Mounting aids
- 3.3 - Hand Stop, Stop Log, Stop Gate with angle frame
- 3.4 - Hand Stop, Stop Log, Stop Gate with anchor bolts for embedding

4. COMMISSIONING

- 4.1 - General measures
- 4.2 - Function test

5. MAINTENANCE

- 5.1 - Operating cycles
- 5.2 - Cleaning / Lubrication

6. REMOVAL

7. DISPOSAL

8. FINAL REMARKS

Version 2012.08

1. GENERAL

1.1 Safety

Prior to any work or start-up and in order to ensure a proper functioning of our products, the instruction manual for installation and operation must be read.

Alterations on the products need our written approval. For consequential damages due to neglect of this direction, any liability will be rejected.



This symbol refers to important information.

The installation must be carried out according to established procedures and only by qualified personnel.

Project related data of valves, e.g. dimensions, materials and service range are found in the respective documentation.

1.2 Designated service

Wey® Hand Stop, Wey® Stop Log und Wey® Stop Gate are frameless valves for channel installations. They are suitable for shutting off inlets and outlets of channels, pits and basins for water and wastewater.

The technical application limits referred to in the relevant project data documentation and this maintenance manual must be observed.

Stop Logs made out of aluminum are designed for emergency shut off and are less suitable for permanent use.

2. TRANSPORTATION, STORAGE

2.1 Transportation

The transportation of Water Control Gates shall take place in a careful way. Lifting devices shall not be hooked onto stems nor other actuating components. Water control Gates shall be placed on even surface only, never tilted onto an edge, to prevent distortion of the frame. The equipment shall be protected against exterior damage and atmospheric exposure.

2.2 Storage

Until final installation the equipment shall be stored in a dry, vented area. All function relevant parts shall be suitably covered against humidity, dust or other contamination.

3. INSTALLATION

3.1 Preparation before installation

Onsite construction work details, recesses, walls, etc. shall be checked for accuracy, flatness, finish, etc. before starting with mounting the equipment.

Dimensions of any recesses have to comply with manufacturer's drawings and shall be checked acc. Fig. 1 and Fig. 2.

The walls shall be checked with plumb and level for its perpendicular (fixation of frame) as well as its horizontal and vertical flatness.

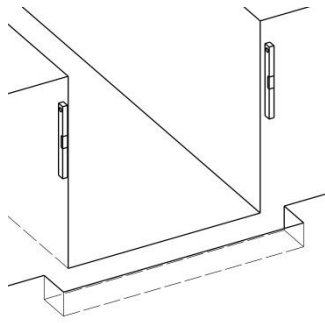

Fig. 1

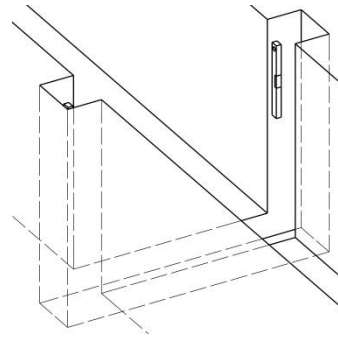

Fig. 2

Larger deviations must be corrected on site prior to mounting, as follows:

- a) by grinding, removal, equalizing of uneven surface;
- b) by applying concrete filler according to requirements (tightness, strength).

3.2 Mounting aids

In order to offset construction discrepancies, plastic or stainless steel shims or spacer plates in various thickness may be used to level and position the fixing frame. Minor discrepancies can be compensated that way. The frame gets therewith enough wall support that it cannot be distorted when tightening the fixing bolts.

Major discrepancies must be compensated with threaded rods of suitable size if assigned bolts are too short (bad concrete quality, anchor hole too long or if many spacer plates had to be used). Cut to size threaded rods must be inserted and tightened with 2 nuts. After tightening the counter nuts must be removed and the threaded rod can be used in replacement of a short bolt.

To seal between frame and wall, paste type, medium resistant sealants are most suitable.



If filler or sealant is used, observe manufacturer's instructions with priority.

3.3 Hand Stop, Stop Log, Stop Gate with angle frame



Mounting and embedding work shall take place with Water Control Gate in completely closed position only. For best sealing between wall and frame, the wall construction must be dry.

Procedure:

- Position Hand Stop, Stop Log, Stop Gate in the respective recess and align with plumb and level, acc. Fig. 3. For Water Control Gates without bottom profiles, position the respective frame sections.
- Depending on the size of the Water Control Gate, 1-2 dowels per side should be set to fix frame temporarily with bolts.
- Check alignment with plumb and level. Readjust position of Water Control Gate, if necessary.



Upper level of bottom profile must comply with **finished floor level** according to site plan.

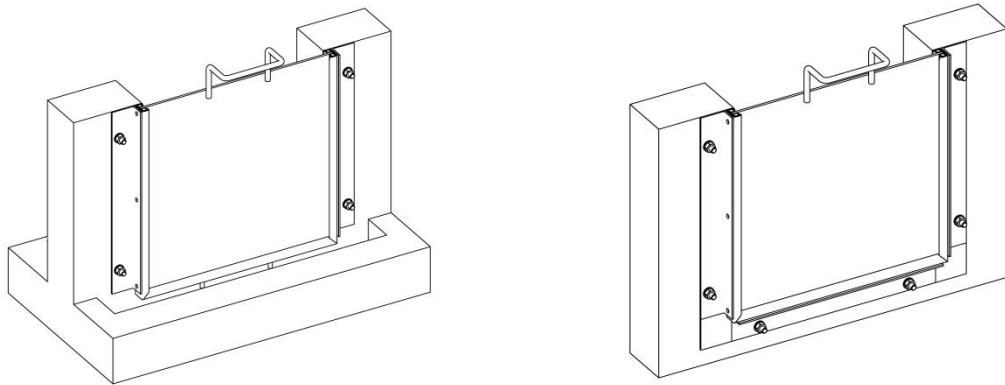

Fig. 3

- Drill and set remaining dowels for all clamps and also on the transverse seal, if applicable.
- Prior to final fixation, pull frame slightly away from the wall in order to place two rows of sealant (according supplier's instructions) behind the frame and transverse seal up to the max. height of water head, respectively to the transverse seal (Fig. 4). If bottom seal is bolted, sealant shall also be placed there.
- All bolts can then be firmly tightened with the **torque key**, according to the product/**supplier's specification**, starting at the transverse seal and afterwards the clamps.

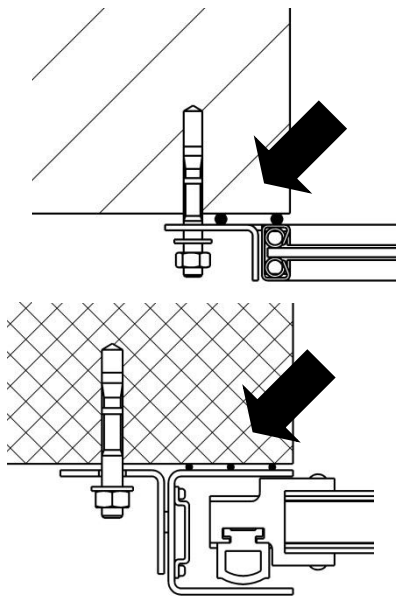

Fig. 4

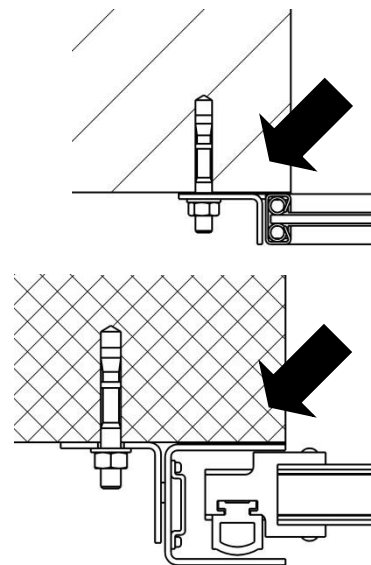

Fig. 5

- When tightening the bolts, the sealant gets squeezed out on both sides of the frame. Smoothen sealant with finger to a clean grout (Fig. 5).
- The bottom profile, if existent, requires onsite embedding with filler or mortar acc. Fig. 6.



When filling these recesses **never use any vibrators!**

Bottom and transverse seal profile shall be free of any concrete or other contamination.

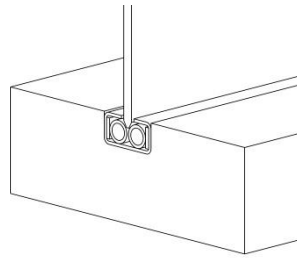

Fig. 6

3.4 Hand Stop, Stop Log, Stop Gate with anchor bolts for embedding



Mounting and embedding work shall take place with gate in completely closed position only.

Procedure:

- Depending on size and weight of Water Control Gate, 2-3 dowels per side should be set into the recess and bolts be inserted (Fig.7).
- Position Hand Stop, Stop Log, Stop Gate in the respective recess and align with plumb and level. For Water Control Gates without bottom profiles, position the respective frame sections.
- Heavy Stop Logs with bottom profile should be aligned and fixed with leveling screws (Fig.8)
- Connect anchor and dowel bolts in the recess with a bar profile by welding (Fig. 7).



Always position Water Control Gate with mounting aids of steel, never use wood wedges. Water Control Gate must never be weld-connected to concrete reinforcement bars.

Water Control Gates without bottom profile:

The frame profiles must be mounted parallel to each other.



Versions with sealing within frame:

The sealing must be placed behind the gate (Fig. 4), not on pressurized side.



Upper level of bottom profile to comply with **finished floor level** according to site plan.

- Check alignment with plumb and level. Realign Water Control Gate, if necessary.
- Remove any auxiliary beams
- For checking parallelism and ease, insert gate temporary
- The positioned Water Control Gate is now ready for onsite embedding.



When filling these recesses **never use any vibrators!**

Bottom and transverse seal profile shall be free of any concrete or other contamination.

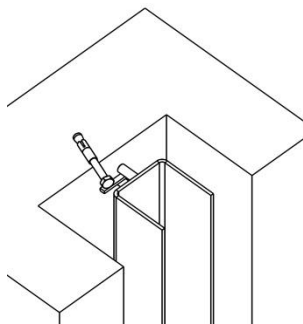

Fig.7

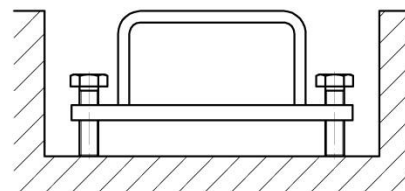

Fig.8

4. COMMISSIONING

4.1 General measures

Before taking the equipment into service, all function relevant parts shall be thoroughly cleaned.

4.2 Function test

Before commissioning a function test must be performed.

Check gate for ease of operation (reasonable forces).

For embedded Water Control Gates a function test shall not take place before grout compound is dry and capable of bearing the structure.

5. MAINTENANCE

5.1 Operating cycles

During one year, at least four (4) operating cycles shall be performed. Under severe service conditions, such functional checks shall take place more frequently.

5.2 Cleaning / Lubrication

Gate guides and sealing shall be free of dirt and contaminations.

The elastomer seal in the gate guides shall also be lubricated to avoid sticking tendency of gate and seal after longer shutdown periods.

Water-repellent, temperature resistant and long lasting lubricants shall be used (Get recommendations from your supplier).

6. REMOVAL

Water Control Gate frames will normally not be removed. They remain fixed to the wall construction for service life.

7. DISPOSAL

Be aware that sediments or contaminations as well as lubricants, cleansers etc. which may adhere to the equipment or pipe could be harmful to people and environment. Respective precaution measures are to be taken.

After finished service life, the valve must be disposed skilful and in conformity with environmental regulations.

8. FINAL REMARKS

All information presented are to the best of our knowledge and shall provide, in combination with our technical documentation, information about our products and their range of applications.

They are not thought to assure particular features of the products nor their suitability for a specific service.

Faultless quality is assured within our General Sales Conditions.

For any further information, call on our Customer Service Department at any time.

Alterations reserved